

Revision

A 4940

New Title
Block
MLM 8/19/14

CSA-0-1-1-00033

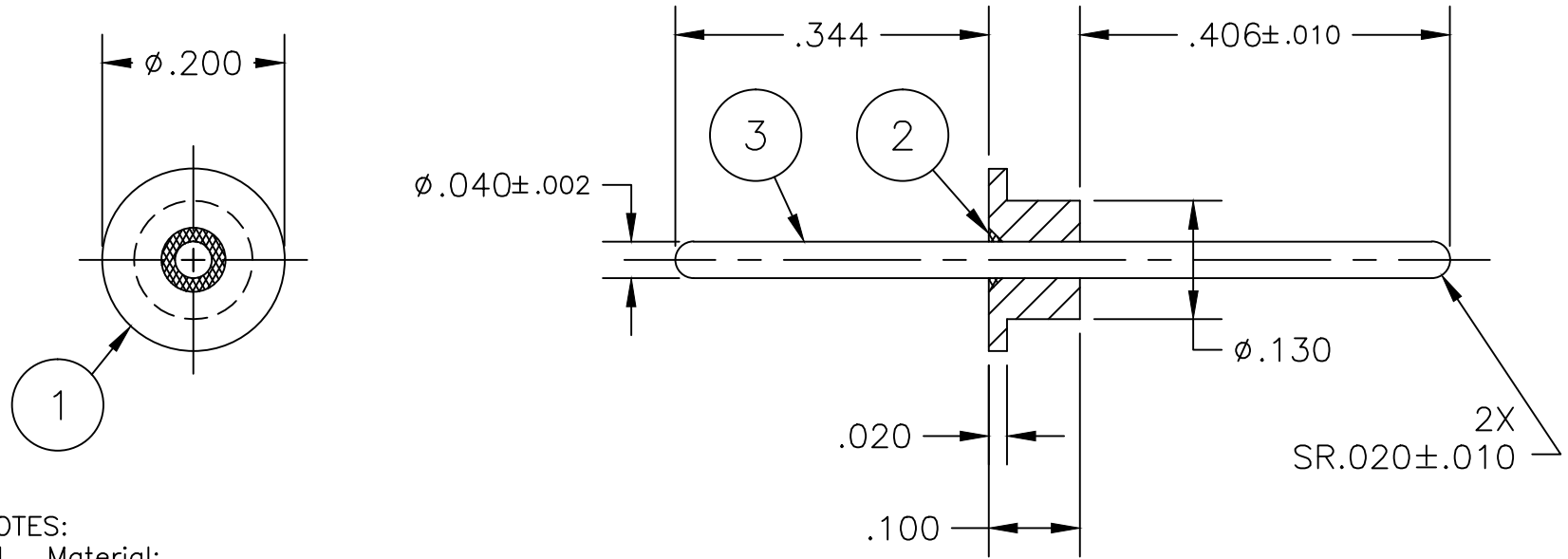

NOTES:

1. Material:
 - 1.1. Eyelet - C1213-C1215 C.R.S.
 - 1.2. Electrode - #52 Alloy
 - 1.3. Braze - AWS #8 BAg-8 (BT)
2. Finish: 100-300 microinches matte Tin/Lead plating (lead content to be 3% minimum balance tin) over 100-300 microinches Sulfamate Nickel per QQ-N-290.
 - 2.1. Plating Area - 0.203 in²
3. Solderability of all metal parts to meet or exceed MIL-STD-202, Method 208.

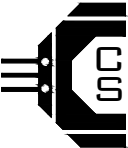
	Aligning Plate	1PF	CSF-0-1-1-00007	SHEET 1 OF 1		 CENTURY SEALS Seaford, DE 19973 (302) 629-0324 www.centuryseals.com
	B/F Assembly	341AL	CSF-0-7-1-00007	UNLESS OTHERWISE SPECIFIED ALL DIMENSIONS ARE IN INCHES		
3	Electrode	1	CPC-3-1-1-00020	DECIMALS	ANGULAR	TOLERANCES .XX = ±.01 ±5° .XXX = ±.005 DO NOT SCALE .XXXX = ±.0005 DRAWING
2	Braze	1	CSC-4-1-2-00003	Drawn/Date	AB 6/20/11	
1	Eyelet	1	CPC-1-2-1-00004	App'd/Date	CJ 6/22/11	
#	DESCRIPTION	QTY	PART NUMBER			TERMINAL ASSEMBLY P/N: CSA-0-1-1-00033 CAGE CODE: 3BW86
						Rev. A