

Revision

A 4940

New Title  
Block  
MLM 8/19/14

CSA-0-1-1-00041

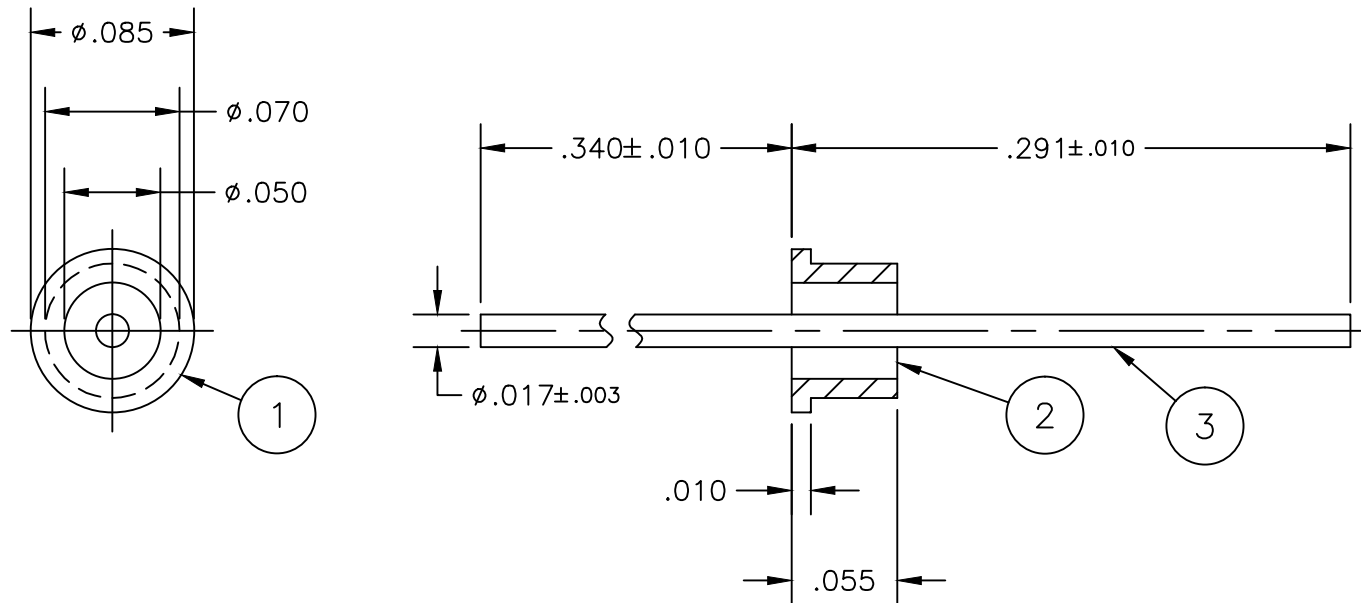

## NOTES:

1. Material:
  - 1.1. Eyelet - C1213-C1215 C.R.S.
  - 1.2. Electrode - #52 Alloy
  - 1.3. Glass - Corning 9013 or equivalent
2. Finish: 50 microinches minimum Gold plating per ASTM B488 Type III, Code A over 100-200 microinches Electroless Nickel per AMS C26074 Class 4.
  - 2.1. Plating Area - 0.052 in<sup>2</sup>
3. Solderability of all metal parts to meet or exceed MIL-STD-202, Method 208.

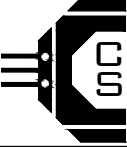
	Aligning Plate	1PF	CSF-0-1-1-00001	SHEET 1 OF 1		 <b>CENTURY SEALS</b> Seaford, DE 19973 (302) 629-0324 <a href="http://www.centuryseals.com">www.centuryseals.com</a>
	B/F Assembly	581AL	CSF-0-7-1-00001	UNLESS OTHERWISE SPECIFIED ALL DIMENSIONS ARE IN INCHES TOLERANCES		
3	Electrode	1	CPC-3-1-1-00002	DECIMALS .XX = ±.01 .XXX = ±.005 .XXXX = ±.0005	ANGULAR ±5° DO NOT SCALE DRAWING	<b>TERMINAL ASSEMBLY</b> P/N: CSA-0-1-1-00041 CAGE CODE: 3BW86
2	Pellet	1	CSC-2-1-4-00001	Drawn/Date	AB 6/20/11	
1	Eyelet	1	CPC-1-2-1-00001	App'd/Date	CJ 6/22/11	
#	DESCRIPTION	QTY	PART NUMBER			

CSA-0-1-1-00020 REV. A