

Revision

A 4940

New Title

Block

MLM 8/19/14

CSA-0-1-1-00043

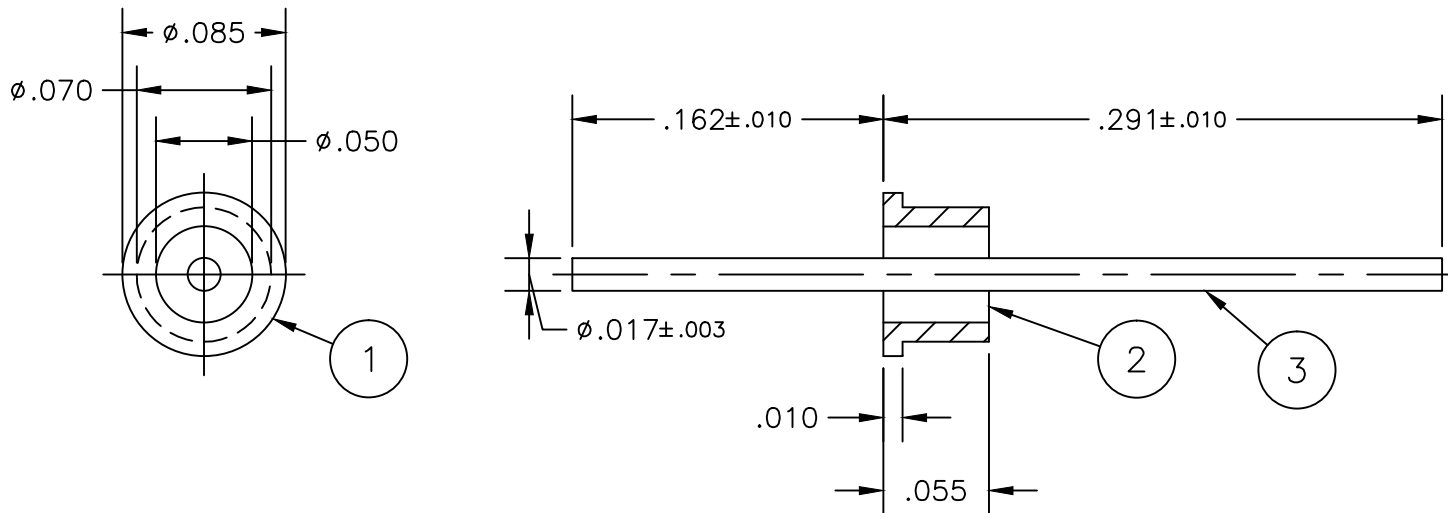

NOTES:

1. Material:
 - 1.1. Eyelet – C1213–C1215 C.R.S.
 - 1.2. Electrode – #52 Alloy
 - 1.3. Glass – Corning 9013 or equivalent
2. Finish: 50 microinches minimum Gold plating per ASTM B488 Type III, Code A over 100–200 microinches Electroless Nickel per AMS C26074 Class 4.
 - 2.1. Plating Area – 0.042 in²
3. Solderability of all metal parts to meet or exceed MIL–STD–202, Method 208.

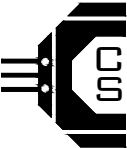
	Aligning Plate	1PF	CSF-0-1-1-00001	SHEET 1 OF 1		 CENTURY SEALS Seaford, DE 19973 (302) 629-0324 www.centuryseals.com
	B/F Assembly	581AL	CSF-0-7-1-00001	UNLESS OTHERWISE SPECIFIED ALL DIMENSIONS ARE IN INCHES TOLERANCES		
3	Electrode	1	CPC-3-1-1-00001	DECIMALS .XX = ±.01 .XXX = ±.005 .XXXX = ±.0005	ANGULAR ±5° DO NOT SCALE DRAWING	TERMINAL ASSEMBLY P/N: CSA-0-1-1-00043 CAGE CODE: 3BW86
2	Pellet	1	CSC-2-1-4-00001	Drawn/Date	AB 6/20/11	
1	Eyelet	1	CPC-1-2-1-00001	App'd/Date	CJ 6/22/11	
#	DESCRIPTION	QTY	PART NUMBER			

CSA-0-1-1-00023 REV. ORIG.