

Revision

A 4940

New Title
Block
MLM 8/19/14

CSA-0-1-2-00044

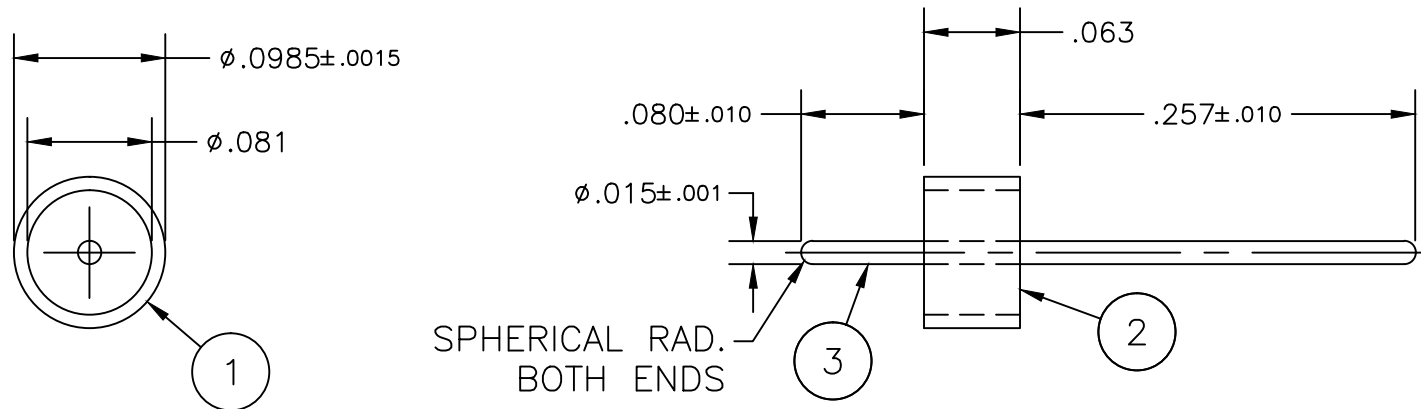

NOTES:

1. Material:
 - 1.1. Eyelet & Electrode – Kovar
 - 1.2. Glass – Corning 7070
2. Finish: 50 microinches min. High Purity Gold per ASTM B488, Type III, Code A over 50–150 microinches Electrolytic Nickel per QQ-N-290.
 - 2.1. Plating Area – 0.041 in^2
3. Hermeticity: $1 \times 10^{-8} \text{ CC/Sec}$ @ one atmosphere.
4. Solderability of metal parts per MIL-STD-202, Method 208.

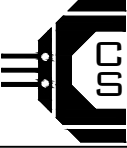
	Aligning Plate	1PF	CSF-0-1-2-00022	SHEET 1 OF 1		 CENTURY SEALS Seaford, DE 19973 (302) 629-0324 www.centuryseals.com
	B/F Assembly	581AL	CSF-0-7-2-00063	UNLESS OTHERWISE SPECIFIED ALL DIMENSIONS ARE IN INCHES TOLERANCES		
3	Electrode	1	CPC-3-1-3-00180	DECIMALS	ANGULAR	DO NOT SCALE DRAWING
2	Pellet	1	CSC-2-1-7-00014	.XX = ±.01	±5°	
1	Eyelet	1	CPC-1-2-2-00004	.XXX = ±.005		
#	DESCRIPTION	QTY	PART NUMBER	App'd/Date	CJ 6/22/11	
				Drawn/Date	AB 6/21/11	TERMINAL ASSEMBLY
						P/N: CSA-0-1-2-00044
						CAGE CODE: 3BW86
						Rev. A

CSA-0-1-2-00044 REV. B